

****DO NOT EXCEED RECOMMENDED VEHICLE TOWING WEIGHT!****

60648 SUBKIT 99-07, CHEVY / GMC 1500 & 2500LD SILVERADO / SIERRA CLASSIC BODY ONLY - ALL BEDS
01-10, CHEVY / GMC 2500HD & 3500 SILVERADO / SIERRA CLASSIC & NEW BODY - ALL BEDS

9/28/2015

PAGE 1 OF 5

WARNING!! BRAKE, FUEL, AND ELECTRICAL LINES MAY NEED TO BE LOOSENED OR REPOSITIONED TO PROVIDE CLEARANCE FOR NEW HARDWARE. SOME MODELS MAY REQUIRE MODIFICATION OR REMOVAL OF HEAT SHIELDS. ON SHORT BED MODELS, CHECK FOR ADEQUATE TURNING CLEARANCE BETWEEN THE FRONT OF ALL TRAILERS AND THE TRUCK CAB. ON TWO WHEEL DRIVE TRUCKS A CLEARANCE CHECK MUST BE PERFORMED WHEN TRUCK IS LOADED AND UNLOADED TO VERIFY THE INVERTED BALL WILL NOT INTERFERE WITH THE TOP OF THE DIFFERENTIAL

****REMOVE ALL REAR WINDOW ACCESSORIES BEFORE TOWING****

Parts List				Parts List			
ITEM	QTY	PART NUMBER	DESCRIPTION	ITEM	QTY	PART NUMBER	DESCRIPTION
1	2	CM-1201-UBS	1/2-13 x 4 1/8 x 6 3/4 x 1 1/2 SQ U-BOLT	12	2	3_4 FW	FLAT WASHER
2	2	CM-1202-UBS	1/2-13 x 4 3/4 x 8 3/4 x 2 SQ U-BOLT	13	2	3_4 - 10 x 2 1/2 HEX	HEX HEAD BOLT-NC
3	2	5/8-11	HEX FLANGE NUT	14	2	3_4 - 10 HFN	HEX FLANGE NUT
4	2	5/8-11 x 1 3_4, GR8	CARRIAGE BOLT	15	2	60648-SP	.375" OBOUND SPACER
5	2	CM-SP9	.250 x 1.25 x 2.50" SQUARE HOLE SPACER	16	2	CM-11-CTM	CABLE TIE MOUNT 1 X 1 UV BLACK
6	6	1_2 - 13 x 1 1_2 HEX, GR8	HEX BOLT	17	2	CM-116415-CT	CABLE TIE 11/64 X 15" 50# UV BLACK
7	6	1/2	CONICAL TOOTHED WASHER	18	2	1/2 PNBR	1/2" PUSHNUT BOLT RETAINER
8	4	1/2-13 x 1 1/2, GR8	CARRIAGE BOLT	19	1	1_2 FISHWIRE	1/2" FISHWIRE
9	8	HFN 1213, GR8	HEX FLANGE NUT	20	1	CM-EBB	11GA. ELECTRICAL BOX BRACKET
10	1	CM-SP12	.250 x 1.00 x 2.00" SQUARE HOLE SPACER				
11	4	CM-SP13	2.50 DIA. x .250" ROUND HOLE SPACER				

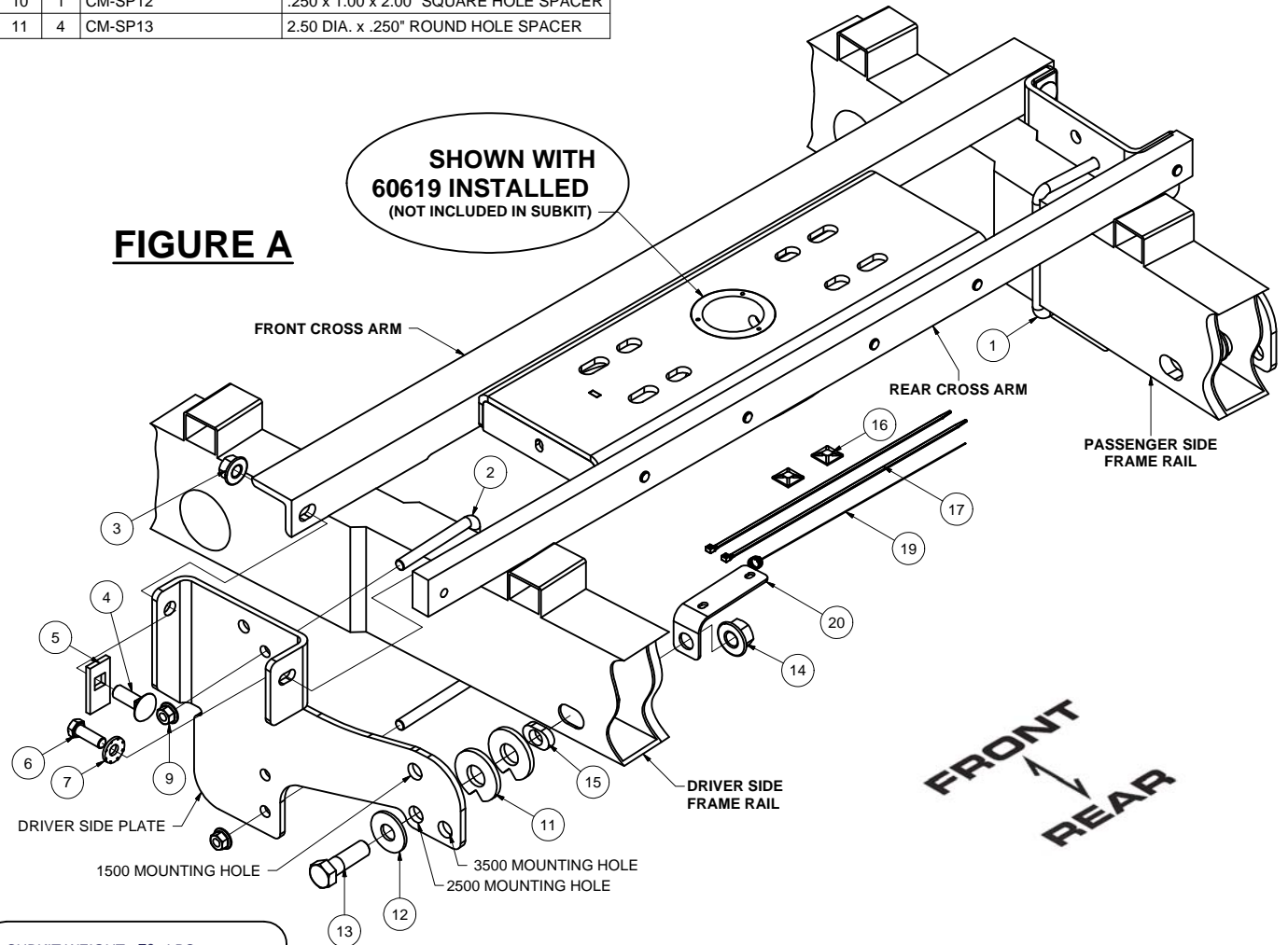

SUBKIT WEIGHT: 70 LBS.

INSTALL TIME

PROFESSIONAL: 45 MINUTES

NOVICE (DIY): 90 MINUTES

INSTALL NOTES:

- TRIM OR REMOVE HEAT SHIELD
- LOWER SPARE TO EASE INSTALL
- NO DRILLING REQUIRED

PERIODICALLY CHECK THIS GOOSENECK HITCH TO ENSURE THAT ALL FASTENERS ARE TIGHT AND THAT ALL STRUCTURAL COMPONENTS ARE SOUND.

Curt Manufacturing Inc., warrants this product to be free of defects in material and/or workmanship at the time of retail purchase by the original purchaser. If the product is found to be defective, Curt Manufacturing Inc., may repair or replace the product, at their option, when the product is returned, prepaid, with proof of purchase. Alteration to, misuse of, or improper installation of this product voids the warranty. Curt Manufacturing Inc.'s liability is limited to repair or replacement of products found to be defective, and specifically excludes liability for incidental or consequential loss or damage.

****DO NOT EXCEED RECOMMENDED VEHICLE TOWING WEIGHT!****

60648 SUBKIT 99-07, CHEVY / GMC 1500 & 2500LD SILVERADO / SIERRA CLASSIC BODY ONLY - ALL BEDS
01-10, CHEVY / GMC 2500HD & 3500 SILVERADO / SIERRA CLASSIC & NEW BODY - ALL BEDS

PAGE 2 OF 5

WARNING!! BRAKE, FUEL, AND ELECTRICAL LINES MAY NEED TO BE LOOSENED OR REPOSITIONED TO PROVIDE CLEARANCE FOR NEW HARDWARE. SOME MODELS MAY REQUIRE MODIFICATION OR REMOVAL OF HEAT SHIELDS. ON SHORT BED MODELS, CHECK FOR ADEQUATE TURNING CLEARANCE BETWEEN THE FRONT OF ALL TRAILERS AND THE TRUCK CAB. ON TWO WHEEL DRIVE TRUCKS A CLEARANCE CHECK MUST BE PERFORMED WHEN TRUCK IS LOADED AND UNLOADED TO VERIFY THE INVERTED BALL WILL NOT INTERFERE WITH THE TOP OF THE DIFFERENTIAL

- 1) Remove spare tire and heat shield. The heat shield under the bed floor needs to be removed or a section cut out for the hitch assembly to be installed. If cut, trim the heat shield from in front of the bed support over the axle to the back of the bed support near the front of the wheel well.

****NOTE: Before installing crossarms, run a 1/2"-13 bolt or 1/2"-13 tap through crossarm holes to remove any powder or debris.****

- 2) Install the rear crossarm by sliding it between the frame and truck bed floor above the passenger side rear tire. After spanning the frames, rotate the cross arm vertically with the holes towards the bottom. **On 1 ton applications**, slide the crossarm through toward the front of the third truck bed rail.

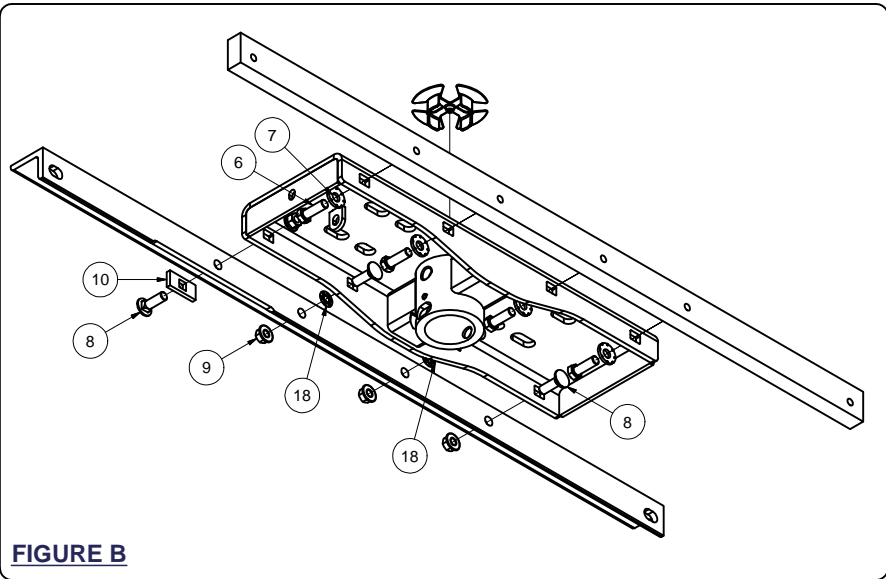

- 3) Install the front crossarm by sliding it between the truck frame and truck bed above the passenger side rear tire. With the crossarm spanning the truck frame, rotate it vertically with the holes towards the bottom. Notch the bed flange as required if needed.
- 4) Install the center section by carefully raising it above the fuel tank from beneath the truck. **OPTIONAL:** Two pushnut bolt retainers (11) are included to give a "helping hand" to the installation process. If desired, put two 1/2" x 1 1/2" carriage bolts (3) in through the centermost slots on the front side of the center section. Be sure the serrations in the bolt retainers are angled away from the center section and push a bolt retainer onto the two carriage bolts. Use one of the included spacers as a tool to push the bolt retainers into position, see **FIGURE C**. Install the fasteners as shown above in **Figure B**, noting that the hole above the driver side front hole over the fuel tank uses a carriage bolt, spacer and nut. A 1/2" fishwire has been include to aid in the placement of the carriage bolt and spacer. Thread them only finger tight into the crossarms.

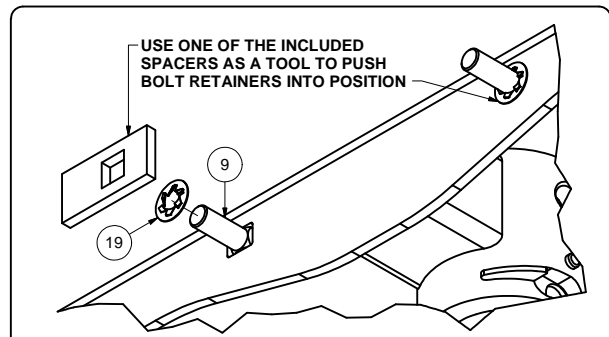

- 5) Install the sideplates, aligning the large holes with the existing slot in the frame. **For '07 and up 2500 & 3500 new body styles:** Remove the electrical box on the inside of the driver side frame and attach it using the supplied electrical box bracket. Attach the bracket to the frame with the 3/4" bolt used to attach the sideplate, using the obround spacers provided to fill the slot in the frame.
- 6) Attach the sideplate flanges to the cross arms using a 1/2" x 1 1/2" hex bolt with 1/2" conical tooth washer and 5/8" x 1 3/4" carriage bolt, CM-SP9, and 5/8" flange nut. Thread them through the inside of the sideplate flanges into the crossarms. **(Finger tight only!)**

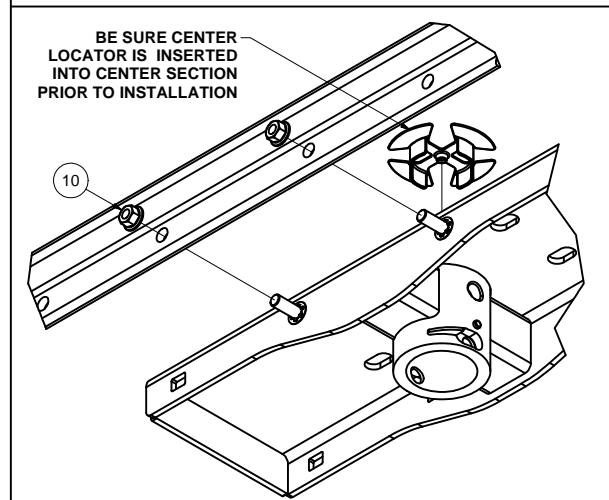

FIGURE C (OPTIONAL "HELPING HAND")

Installation steps continued on page 3

PERIODICALLY CHECK THIS GOOSENECK HITCH TO ENSURE THAT ALL FASTENERS ARE TIGHT AND THAT ALL STRUCTURAL COMPONENTS ARE SOUND.

Curt Manufacturing Inc., warrants this product to be free of defects in material and/or workmanship at the time of retail purchase by the original purchaser. If the product is found to be defective, Curt Manufacturing Inc., may repair or replace the product, at their option, when the product is returned, prepaid, with proof of purchase. Alteration to, misuse of, or improper installation of this product voids the warranty. Curt Manufacturing Inc.'s liability is limited to repair or replacement of products found to be defective, and specifically excludes liability for incidental or consequential loss or damage.

****DO NOT EXCEED RECOMMENDED VEHICLE TOWING WEIGHT!****

60648 SUBKIT 99-07, CHEVY / GMC 1500 & 2500LD SILVERADO / SIERRA CLASSIC BODY ONLY - ALL BEDS
01-10, CHEVY / GMC 2500HD & 3500 SILVERADO / SIERRA CLASSIC & NEW BODY - ALL BEDS

PAGE 3 OF 5

WARNING!! BRAKE, FUEL, AND ELECTRICAL LINES MAY NEED TO BE LOOSENED OR REPOSITIONED TO PROVIDE CLEARANCE FOR NEW HARDWARE. SOME MODELS MAY REQUIRE MODIFICATION OR REMOVAL OF HEAT SHIELDS. ON SHORT BED MODELS, CHECK FOR ADEQUATE TURNING CLEARANCE BETWEEN THE FRONT OF ALL TRAILERS AND THE TRUCK CAB. ON TWO WHEEL DRIVE TRUCKS A CLEARANCE CHECK MUST BE PERFORMED WHEN TRUCK IS LOADED AND UNLOADED TO VERIFY THE INVERTED BALL WILL NOT INTERFERE WITH THE TOP OF THE DIFFERENTIAL

Installation steps continued

- 7) Attach the sideplates to the frame of the truck using a U-bolt and 3/4" hex bolt. **For 3/4 and 1 ton applications**, use the large U-bolt in order to span the truck frame. The smaller U-bolt is used for **1/2 ton and 3/4 ton light duty trucks**. Position the U-bolt from the inside of the truck frame, make sure not to damage or pinch the wiring harness or brake lines. Attach to the sideplate using two 1/2" flange nuts. **(Finger tight only)** Attach the rear section of the sideplate to the frame using a 3/4" hex bolt and 3/4" washer through the sideplate and frame. Finger tighten a 3/4" flange nut to the bolt on the inside of the frame. **For 3/4 and 1 ton heavy duty trucks**, use the bottom hole on the sideplate. **For 1/2 ton and 3/4 ton light duty trucks**, use the top hole on the sideplate. These are called out on **Figure A**.
- 8) Torque all 1/2" fasteners to 110 lb-ft, 5/8" fasteners to 210 lb-ft, and all 3/4" fasteners to 380 lb-ft in the following order:
First: Torque the center section to the front and rear crossarms.
Second: Torque the sideplates to the truck frame on both sides. **(When torquing the U-bolts, make sure to tighten them slowly alternating between the top and bottom of the U-bolt until equally tightened to a maximum of 40 ft-lbs.)**
Third: Torque the sideplate flanges to the front and rear crossarms.
- 9) If desired, trim the sideplate u-bolts to provide additional handle rod clearance upon installation completion.

(REFER TO 60619 GOOSENECK HITCH INSTRUCTIONS FOR INSTALLATION COMPLETION AND OPERATING PROCEDURES)

PERIODICALLY CHECK THIS GOOSENECK HITCH TO ENSURE THAT ALL FASTENERS ARE TIGHT AND THAT ALL STRUCTURAL COMPONENTS ARE SOUND.

Curt Manufacturing Inc., warrants this product to be free of defects in material and/or workmanship at the time of retail purchase by the original purchaser. If the product is found to be defective, Curt Manufacturing Inc., may repair or replace the product, at their option, when the product is returned, prepaid, with proof of purchase. Alteration to, misuse of, or improper installation of this product voids the warranty. Curt Manufacturing Inc.'s liability is limited to repair or replacement of products found to be defective, and specifically excludes liability for incidental or consequential loss or damage.

VACUUM CANISTER RELOCATION

PAGE 4 OF 5

Parts List		
ITEM	PART NUMBER	DESCRIPTION
1	CM-11-CTM	CABLE TIE MOUNT 1 X 1 UV BLACK
2	CM-116415-CT	CABLE TIE 11/64 X 15" 50# UV BLACK

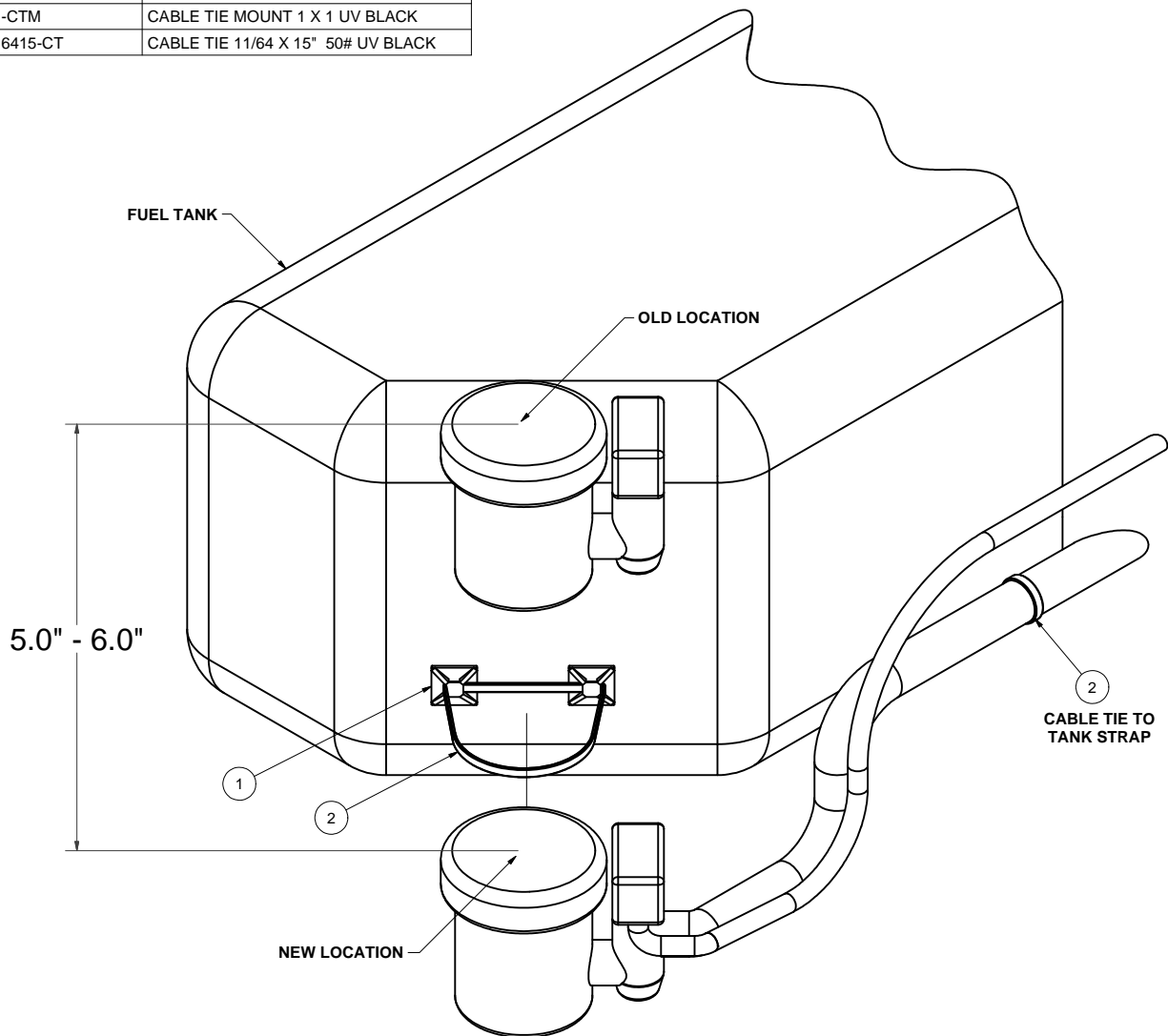

INSTALLATION STEPS

- 1) Remove vacuum canister from OEM mount.
- 2) Clean surface with rubbing alcohol.
- 3) Apply (2) cable tie mounts approximately 3" apart and 5"-6" lower than original location as shown.
- 4) Insert cable tie into mounts. Do Not Fasten.
- 5) Position vacuum canister over cable tie and fasten in new location.

PERIODICALLY CHECK THIS RECEIVER HITCH TO ENSURE THAT ALL FASTENERS ARE TIGHT AND THAT ALL STRUCTURAL COMPONENTS ARE SOUND

Curt Manufacturing Inc., warrants this product to be free of defects in material and/or workmanship at the time of retail purchase by the original purchaser. If the product is found to be defective, Curt Manufacturing Inc., may repair or replace the product, at their option, when the product is returned, prepaid, with proof of purchase. Alteration to, misuse of, or improper installation of this product voids the warranty. Curt Manufacturing Inc.'s liability is limited to repair or replacement of products found to be defective, and specifically excludes liability for incidental or consequential loss or damage.

CAB TO TRAILER CLEARANCE

****DO NOT EXCEED VEHICLE MANUFACTURER'S RECOMMENDED TOWING CAPACITY****

****REMOVAL OF REAR WINDOW ACCESSORIES MAY BE REQUIRED****

TRAILER

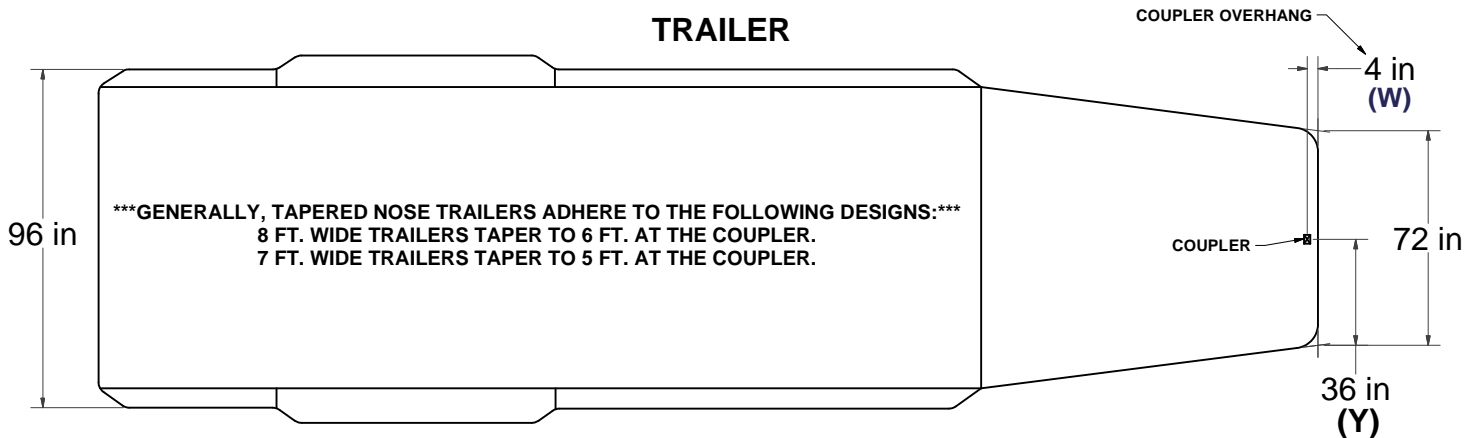

LONG & SHORT TRUCK BEDS

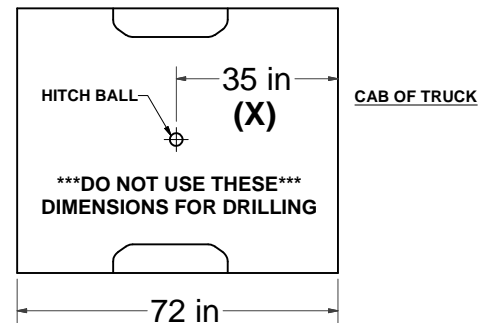
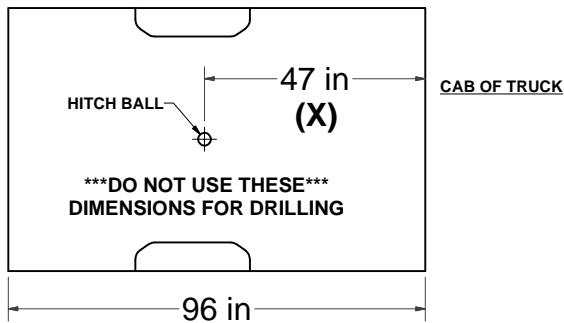

****WARNING REFERENCE CLEARANCE CALCULATOR BEFORE TOWING****

CLEARANCE CALCULATION

$$\begin{matrix} \text{(CAB TO BALL CENTER)} & - & 1/2 \text{ (TRAILER WIDTH)} & = & \text{(MINIMUM CLEARANCE)} \\ \text{(X)} & - & \text{(Y)} & = & \text{(Z)} \end{matrix}$$

IF THERE IS AN OVERHANG FROM THE COUPLER THEN THE EQUATION IS:

$$[(X) - (W)] - (Y) = (Z)$$

*****IF (Z) IS POSITIVE, TRAILER WILL NOT INTERFERE WITH CAB OF TRUCK.***
IF (Z) IS NEGATIVE, TRAILER WILL INTERFERE WITH CAB OF TRUCK!!!**

EXAMPLE:

STANDARD TRAILER

$$\begin{aligned} X - Y &= Z \\ 35 - 36 &= -1 \\ \text{(TRAILER WILL INTERFERE WITH CAB)} \end{aligned}$$

TRAILER WITH OVERHANG

$$\begin{aligned} [(X) - (W)] - Y &= Z \\ [35 - 4] - 36 &= -5 \\ \text{(TRAILER WILL INTERFERE WITH CAB)} \end{aligned}$$

YOUR CALCULATION:

$$\begin{aligned} \text{(CAB TO BALL CENTER)} & \quad \underline{\hspace{2cm}} \\ \text{(COUPLER OVERHANG)} & \quad \underline{\hspace{2cm}} \\ 1/2 \text{ (TRAILER WIDTH)} & \quad \underline{\hspace{2cm}} \\ \text{(MINIMUM CLEARANCE)} & \quad \underline{\hspace{2cm}} \end{aligned}$$

Curt Manufacturing Inc., warrants this product to be free of defects in material and/or workmanship at the time of retail purchase by the original purchaser. If the product is found to be defective, Curt Manufacturing Inc., may repair or replace the product, at their option, when the product is returned, prepaid, with proof of purchase. Alteration to, misuse of, or improper installation of this product voids the warranty. Curt Manufacturing Inc.'s liability is limited to repair or replacement of products found to be defective, and specifically excludes liability for incidental or consequential loss or damage.

INSTALLATION INSTRUCTIONS

WARNING: NEVER EXCEED YOUR VEHICLE MANUFACTURER'S RECOMMENDED TOWING CAPACITY

DOUBLE LOCK EZTTM GOOSENECK HITCH



MAINTENANCE

Keep gooseneck ball, cylinder and trailer coupler lubricated regularly. Use silicone spray or equivalent to prevent wear / rust.

Keep hitch assembly and trailer coupler free of dirt and other foreign debris. Periodically check the gooseneck hitch to ensure that all fasteners are tight and that all structural components are sound.

When the gooseneck ball is in the inverted position insert the supplied rubber hole cover to keep out dirt and debris.

PARTS LIST

Item#	Qty	Description
1	1	Gooseneck center section
2	1	Center locator / trim shield
3	1	Rubber cover
4	1	Gooseneck ball, 2 5/16"
5	1	Handle assembly
6	1	Chrome ring, 3 3/4" x 3/4"
7	1	Cast lock pin
8	1	Compression spring, 7 1/2 lbs.
9	1	U-shaped edging, 1/3"
10	2	U-bolt, 5/8"
11	4	U-bolt spring
12	4	Nylock nut, 5/8"
13	8	USS washer, 5/8"
14	2	Washer, 3/8"
15	1	Hex head flange screw, 30mm
16	1	Nylock hex nut, M5
17	3	Flat head cap screw, 20mm

WARNINGS

Brake, fuel and electrical lines may need to be loosened or repositioned to provide clearance for new hardware. Some models require modification or removal of heat shields. On short bed models, check for adequate turning clearance between the front of all trailers and the truck cab. On two-wheel drive trucks a clearance check must be performed when the truck is loaded and unloaded to verify the inverted ball will not interfere with the top of the differential.

Vehicle performance (braking, handling, acceleration, turning radius) can be drastically affected by the trailer. Allow additional time / space for stopping, changing lanes, passing and turning.

TOOLS LIST

Safety glasses	Drill bit, 3/16"
Ear protection	Hole saw, 4" & 5/8"
Ratchet	Allen wrench, #3
Socket, 8mm, 15/16"	Cutting fluid
End wrench, 8mm	Rust inhibitor
Drill	

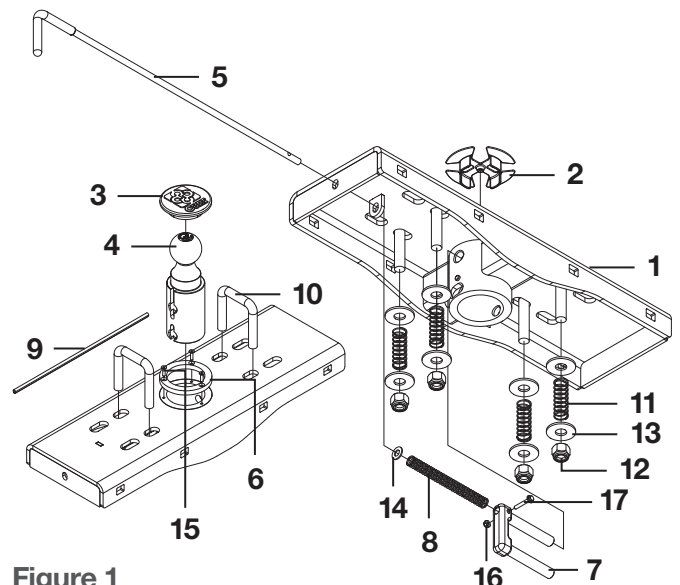

Figure 1

INSTALLATION

Step 1

Using a 3/16" drill bit, drill a pilot hole from underneath the truck bed through the hole in center locator / trim shield (#2). See figure 2.

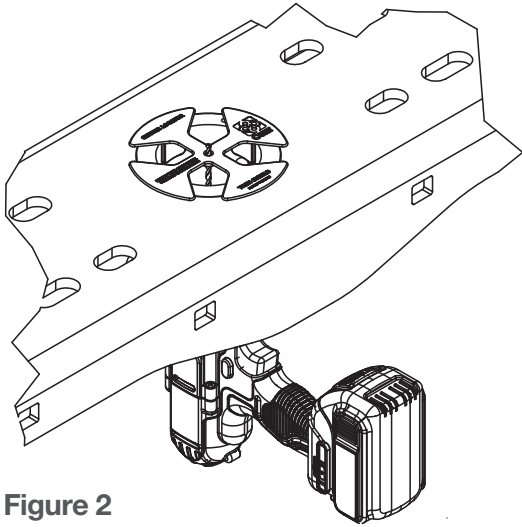

Figure 2

Step 2

Determine the correct safety chain hole locations for the vehicle; refer to figure 3 below. Using a 5/8" hole saw and the gooseneck center section (#1) as a guide, drill four holes from underneath the truck bed for the safety chain loops. Drill holes should go through the low rib sections. See figure 4 for correct placement.

To ensure smooth operation of the safety chain loops, use a 3/4" step bit to slightly enlarge the holes from above the truck bed.

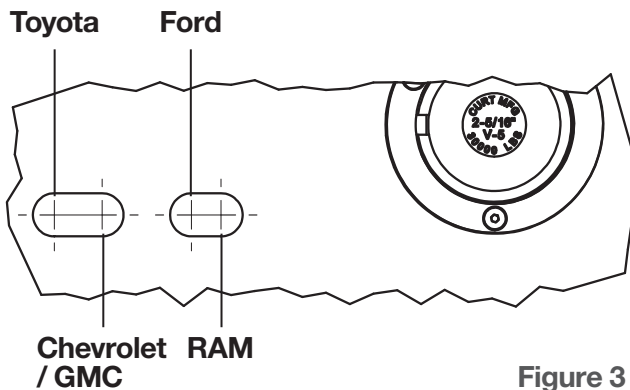

Figure 3

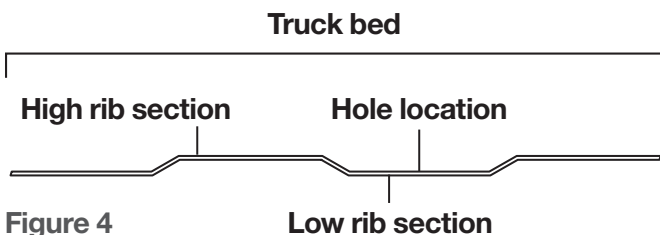

Figure 4

Step 3

Using a 4" hole saw, drill the hole from above the truck bed. Take caution to not drill through the center locator / trim shield (#2) **Note:** The use of cutting fluid will ease this process. Remove the center locator by pulling it up through the hole.

Step 4

Deburr the cut holes and spray exposed metal with rust inhibitor. **Optional:** Insert rubber edging (#9) around the 4" hole. Place the chrome trim ring (#6) into position and fasten with three head cap screws (#17). Place two U-bolts (#10) down through the holes drilled in step 2.

Step 5

From underneath the truck; place a 5/8" washer (#13), spring (#11), 3/8" washer (#14) and 5/8" nylock nut (#12) on each of the four U-bolt legs. Tighten the nuts until flush with the bottom of the U-bolt; see figure 1.

Step 6

Insert the cast lock pin (#7) into the ball cylinder with the handle hole located on top. Insert the handle (#5) from the outside of the vehicle through the holes in the center section; see figure 1. **Note:** Some models may require the use of a pliers to bend the metal flange below the bed outward, allowing the handle to move without interference.

Step 7

Slide one 3/8" washer (#14) and the compression spring (#8) over the handle before inserting the handle (#5) into the lock pin (#7). Insert the handle into the locking pin and secure with a hex head flange screw (#15) and nylock nut (#16); see figure 1. **Note:** If needed, add or remove a 3/8" washer (#14) to ensure proper pull length of locking pin.

Step 8

If removed, reinstall plastic wheel-well covers. **Note:** Some models may require trimming of the plastic wheel-well cover. Trim as needed for reinstallation and access to the handle. Reinstall the spare tire.

OPERATION

Step 1

Place the handle in the unlock position by pulling it out as far as possible and rotating it clockwise. **Note:** Never operate the vehicle with the handle in the unlocked position.

Step 2

Insert the gooseneck ball into the desired position in the cylinder by aligning the ball's groove with the cylinder pin. If the groove and pin are not aligned, simply rotate the gooseneck ball until it drops into place.

Step 3

Place the handle in the lock position by rotating it counterclockwise until the locking pin snaps back into position.

BEFORE TOWING FOR THE FIRST TIME

Verify adequate turning clearance between the truck cab / box corners and trailer.

Check truck box clearance. There should be a minimum clearance of 6" between the bottom of the trailer overhang and the top of the box sides.

Verify the inverted gooseneck ball will not interfere with the top of the differential when hauling heavy loads. This is especially important on two-wheel drive models.

Verify all hardware is torqued to the proper specification.

Verify the safety chain length. Too much slack in the chain may cause loss of control in the event of trailer-vehicle separation. Leave only enough slack to allow full turning without interference.

Verify that the trailer attachments to the safety chain loops are secure (cannot be shaken free while towing).

BEFORE TOWING EVERY TIME

Ensure all fasteners are tight and that all structural components are sound. **Note:** Do not tow a trailer with worn or damaged parts.

Attach trailer securely to both of the safety chain loops.

Ensure the handle is in the lock position. Confirm the locking pin passes completely through the ball and both walls of the hitch cylinder.

Ensure the trailer weight does not exceed any part of the towing system. Be sure the load is heavier towards front of the trailer while not exceeding the hitch's tongue weight. Be sure trailer load is centered from left to right and secured to prevent shifting. **Note:** Never load the heaviest part of the trailer behind the axle(s).

Check the trailer's tires to ensure they are inflated to the proper specification. Verify trailer lights, electric brakes and breakaway switches are working properly.

CURT WARRANTY

CURT Manufacturing, LLC (CURT) warrants to the original purchaser (Purchaser), its products to be free from defect under normal use and service, ordinary wear and tear excepted, for the warranty period stated below, from the date of the original retail purchase, but subject to the limitations as set forth below.

LIMITATION ON WARRANTY

CURT's obligation under the above warranty is limited to repair or replacement of the CURT Product (Product), at its option due to a manufacturing defect of the Product. CURT shall not be liable for the loss of or use of vehicles, loss of or damage to personal property, expenses such as telephone, lodging, gasoline, towing, tire damage or any other incidental or consequential damages incurred by the Purchaser, or any other person or entity.

CURT will examine the returned Product. If CURT, in its exclusive discretion, determines that the defect or damaged Product is covered under this limited warranty, CURT will repair the Product or replace it at that time.

Alterations to or misuse of the Product will void the warranty. For example, overloading or exceeding an automobile or trailer manufacturers' weight ratings, or maneuvering motor vehicles equipped with Products at improper rate of speed, shall void the warranty on any of the Products. Failure to properly maintain and regularly inspect the Product according to the specific instruction sheet accompanying each Product shall also void the warranty.

Some states do not allow the exclusion or limitation of incidental or consequential damages. If such exclusions or limitations are prohibited under the applicable law, the above limitation or exclusion may not apply.

This Warranty gives you specific legal rights and you may also have other rights, which vary from state to state.

The Purchaser, when returning a CURT Product, must observe the following steps:

1. The Purchaser must have proof of purchase of any damaged Product and supply the same to the headquarters of CURT. The Purchaser must obtain from CURT (toll free number is 877-CURTMFG (877.287.8634)) a Returned Goods Authorization (RGA) number in order to return any damaged Product to CURT for inspection and evaluation under this Limited Warranty.
2. The Purchaser must pay all handling charges and shipping costs to deliver Products to CURT and must send the damaged Product along with the RGA number and proof of purchase to CURT at 6208 Industrial Drive, Eau Claire, Wisconsin 54701.
3. Upon receipt of damaged Product, CURT will determine whether the damaged Product is covered under the Limited Warranty. If it is, CURT will repair or replace the Product. If the Product is replaced, the Product that is originally returned by the Purchaser shall become the exclusive property of CURT. If the returned Product is not covered under the Limited Warranty, CURT will notify the Purchaser before taking any further action with regard to repair or replacement, which would be at the Purchaser's cost.